

Control Valve

# ZK 313

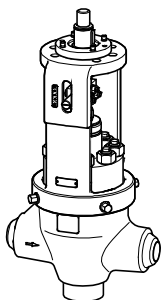
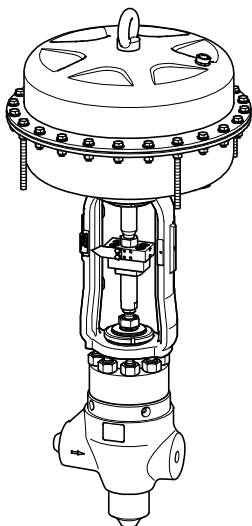

# Contents

|                                                           |           |
|-----------------------------------------------------------|-----------|
| <b>Foreword</b> .....                                     | <b>3</b>  |
| Availability.....                                         | 3         |
| Formatting features in the document .....                 | 3         |
| Shown and described types of equipment .....              | 3         |
| <b>Safety</b> .....                                       | <b>4</b>  |
| Use for the intended purpose .....                        | 4         |
| Basic safety notes .....                                  | 4         |
| Information on property damage or malfunctions .....      | 6         |
| Qualification of personnel.....                           | 6         |
| Protective gear .....                                     | 6         |
| Typographic features of warning notes.....                | 6         |
| Formatting features for warnings of property damage ..... | 7         |
| <b>Description</b> .....                                  | <b>7</b>  |
| Scope of supply and equipment specification .....         | 7         |
| Task and function.....                                    | 15        |
| <b>Storing and transporting the equipment</b> .....       | <b>16</b> |
| Storing the equipment .....                               | 16        |
| Transporting the equipment .....                          | 17        |
| <b>Mounting and connecting the equipment</b> .....        | <b>18</b> |
| Preparing installation .....                              | 18        |
| Connecting the equipment .....                            | 19        |
| Checking the function .....                               | 20        |
| <b>Operating the equipment</b> .....                      | <b>21</b> |
| <b>After operation</b> .....                              | <b>21</b> |
| Maintaining the equipment.....                            | 23        |
| Rinse the equipment.....                                  | 24        |
| Disassembling the equipment.....                          | 26        |
| Assembling the equipment.....                             | 38        |
| Servicing the equipment and installing spare parts .....  | 50        |
| <b>Troubleshooting</b> .....                              | <b>51</b> |
| <b>Putting the equipment out of operation</b> .....       | <b>52</b> |
| Removing harmful substances.....                          | 52        |
| Removing the equipment .....                              | 52        |
| Disposing of the equipment.....                           | 54        |
| <b>Technical data</b> .....                               | <b>54</b> |
| Dimensions and weights .....                              | 54        |
| Fluid flowrate and differential pressure.....             | 55        |
| Pressure & temperature ratings .....                      | 58        |
| <b>Manufacturer's Declaration</b> .....                   | <b>58</b> |

## Foreword

This installation & operating manual (IOM) will help you use the control valve ZK 313 and its variants (referred to as "equipment" in this document) safely and efficiently for its intended purpose.

This installation & operating manual is intended for anyone commissioning, using, operating, servicing, cleaning or disposing of this equipment and, in particular, for professional after-sales service technicians, qualified personnel and authorised and trained staff.

All of these persons must read and understand the content of this installation & operating manual.

Following the instructions given in this installation & operating manual helps avoiding danger and increases the reliability and service life of the equipment. Please note that in addition to the instructions given in this installation & operating manual you must also observe all locally applicable rules and regulations concerning the prevention of accidents as well as approved safety guidelines for good professional practice.

## Availability

Keep this installation & operating manual together with the plant documentation for future reference. Make sure that this installation & operating manual is available to the operator.

The installation & operating manual is part of the equipment. Please hand over this installation & operating manual when selling the equipment or passing it on.

Keep the applicable documents specified on page 7 together with this installation & operating manual for future reference.

## Formatting features in the document

Certain text elements of this installation & operating manual feature a specific typographic design. You can easily distinguish the following text elements:

Standard text

*Cross-reference*

- ▶ Listing
  - ▶ Sub-items in listings
- Steps for action.



Here you will find additional useful information and tips serving to assist you in using the equipment to its fullest potential.

## Shown and described types of equipment

The drawings and descriptions in this installation & operating manual refer to type ZK 313/11.

If any other variant is shown or described it will be explicitly stated.

This installation & operating manual (IOM) describes standard equipment. Contact the manufacturer for more information on the variants and types not described in this document.

## Safety

### Use for the intended purpose

The equipment is designed for controlling and regulating the level, pressure and flowrate of fluids in heat and process control systems.

Correct use includes compliance with the instructions given in this installation & operating manual, in particular obedience to all safety instructions.

Indications and instructions stated in the applicable documents are part of this installation & operating manual.

Any other use of the equipment is considered to be improper.

Note that the equipment is also used incorrectly if the materials of the equipment are not suitable for the fluid.

The equipment is also considered to be used improperly if:

- ▶ the equipment is not in proper working condition when being used
- ▶ the equipment is used in operating conditions that exceed the pressure and temperature ratings and limits stated in this IOM and the applicable documents
- ▶ the equipment is retrofitted or modified without the written approval of the manufacturer
- ▶ the equipment is fitted with spare parts that are not approved by the manufacturer
- ▶ the equipment is provided with an actuator that is not approved by the manufacturer
- ▶ the equipment is operated or serviced by unqualified personnel.

The personnel must have the qualification and experience specified in section "*Qualification of personnel*" on page 6.

## Basic safety notes

### Explosion hazard

- ▶ Explosion risk if equipment is used that is not suitable for the environmental conditions. When using the equipment in explosion risk areas make sure that:
  - ▶ The permissible surface temperature of the equipment for the place of installation must not be exceeded.
  - ▶ If electrically insulated equipment is installed appropriate measures must be taken to discharge any static electricity between pipe flanges.
- ▶ The heat generated by friction caused by moving parts that do not run smoothly can cause explosions. Make sure that all moving parts can operate smoothly.
- ▶ When carrying out welding work in order to install or remove the equipment flying sparks may be generated that can cause fire or explosion. Observe any on-site regulations for fire and explosion prevention. Only qualified personnel is allowed to mount or remove the equipment or its components.

### Risk of severe injuries

- ▶ The equipment may become hot during operation. Do not operate the equipment unless thermal insulation or protection against accidental contact prevents you from touching hot surfaces.
- ▶ The equipment is under pressure during operation and may be hot. Before carrying out any work on the equipment make sure that the following requirements are met:
  - ▶ The pipes must be depressurized (0 bar).
  - ▶ The fluid must be completely removed from the pipes and the equipment.
  - ▶ During work on the equipment the installation must be switched off and protected against unauthorised or unintended activation.
  - ▶ The pipes and the equipment must have cooled down to room temperature (approx. 20 °C).



## Risk of minor injuries

- ▶ Sharp edges on component parts can cause cuts. Always wear industrial gloves when servicing the equipment.
- ▶ The equipment can become hot during operation. This presents the risk of burns caused by heat radiation or when touching the equipment. Do not touch the equipment during operation. Always wear heat resistant protective gear when working on the equipment.

## Information on property damage or malfunctions

- ▶ Malfunctions will occur if the equipment is installed in a wrong position or with the flow arrow pointing in the opposite direction of the fluid flow. This may result in damage to the equipment or the installation. Make sure that the flow arrow on the equipment body matches the indicated direction of the fluid flow in the pipe.
- ▶ If the material is unsuitable for the fluid, increased wear may occur and fluid may escape. Make sure that the material is suitable for the fluid used in your installation.

## Qualification of personnel

A qualified person must be acquainted with and experienced in the following:

- ▶ the pertinent on-site rules and regulations for preventing fire and explosions as well as industrial safety regulations
- ▶ working on pressure equipment
- ▶ making pipe connections
- ▶ working with dangerous (hot or pressurized) fluids
- ▶ lifting and transporting loads
- ▶ observing all notes and instructions in this installation & operating manual and the applicable documents
- ▶ connecting the power supply of the actuator

## Protective gear

The required protective gear depends on the types of fluid used and the regulations on site. For more information on suitable safety clothing and safety gear refer to the safety data sheet of the fluid in question.

Protective gear comprises the following items:

- ▶ protective helmet
- ▶ work boots
- ▶ industrial leather gloves

Wear some form of ear protection when standing close to the equipment (1 m or less) during operation.

## Typographic features of warning notes

---



### DANGER

Notes with the heading DANGER warn against imminent dangerous situations that can lead to death or serious injuries.

---

---



### WARNING

Notes with the heading WARNING warn against possibly dangerous situations that could lead to death or serious injuries.

---

---



### CAUTION

Notes with the heading CAUTION warn against dangerous situations that could lead to minor or moderate injuries.

---

## Formatting features for warnings of property damage

---

### ***Attention!***

This information warns of a situation leading to property damage.

---

## Description

### Scope of supply and equipment specification

#### Scope of supply

Our equipment is delivered packed and ready for assembly.

#### Applicable documents

The following documents are part of the supply of the equipment:

- ▶ Declaration of incorporation
- ▶ Documents provided by the manufacturer of actuator
- ▶ Dimensional drawing with indications of centre of mass
- ▶ Data sheet
- ▶ Parts list

These documents are part of the user documentation and must be kept together with this installation & operating manual for future reference.

#### Equipment specification

The equipment consists of the following main components:

- ▶ Body
- ▶ Upper part
- ▶ Bonnet
- ▶ Nozzle

Different equipment variants are available. The type designation has a code that indicates the respective variant.

- ▶ The equipment is available in sizes between DN 25 and DN 150.
- ▶ The body is available as straight-through or angle-type. The code letter "D" in the type designation indicates straight-through and "E" indicates angle-type. Equipment of size DN 100–DN 150 is of the angle-type, features a hammer-forged body and is indicated by the additional code character "O" in the type designation. A special Z-type hammer-forged body is also available on request.
- ▶ The equipment can be fitted with various types of actuators. The actuator type is indicated by the following code numbers in the type designation:
  - ▶ 02: Handwheel (retrofitting of an electric rotary actuator possible)
  - ▶ 11: Electric rotary actuator
  - ▶ 12: Electric rotary actuator
  - ▶ 13: Electric linear actuator
  - ▶ 20: Pneumatically operated diaphragm actuator or piston actuator
  - ▶ 31: Lever actuator equipped with quarter-turn actuator
  - ▶ 40: Hydraulic cylinder
- ▶ The throttling system has three stages for pressure reduction. Special design versions with one or four stages are available on request.



Note that any special design versions are not described in this installation & operating manual (IOM).

#### Example of type designations

"ZK 313-E/11"

Equipment with angle-type body and electric rotary actuator

"ZK 313-E/20"

Equipment with straight-through body and pneumatic actuator



In most cases the equipment described in this IOM is of the angle-type and has a spindle bearing for an electric rotary actuator.

If any other variant is shown or described it will be explicitly stated.

### **End connections**

The equipment is available with the following end connections:

- ▶ Butt-weld ends
- ▶ Socket-weld ends
- ▶ Flanges

The end connection is not specified in the type designation.



Equipment with socket-weld ends and flanges are special design versions and not described in this IOM.

- For more information on special design versions please contact the manufacturer.



## Component parts

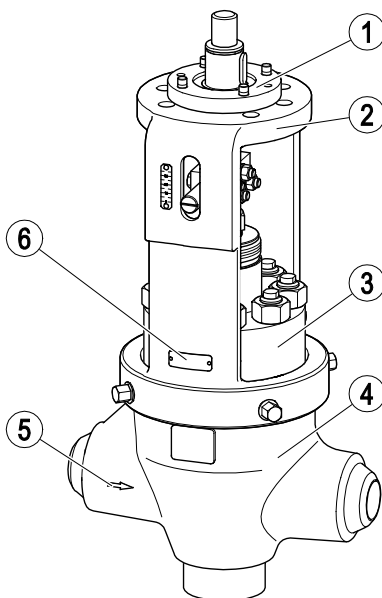

| No. | Designation                                                                                                  |
|-----|--------------------------------------------------------------------------------------------------------------|
| 1   | Mechanical connection for actuator, in equipment with rotary actuator this is a spindle bearing (shown here) |
| 2   | Bonnet                                                                                                       |
| 3   | Upper part                                                                                                   |

| No. | Designation                          |
|-----|--------------------------------------|
| 4   | Body                                 |
| 5   | Flow direction arrow (on both sides) |
| 6   | Name plate                           |

The yoke is fitted with the following items:

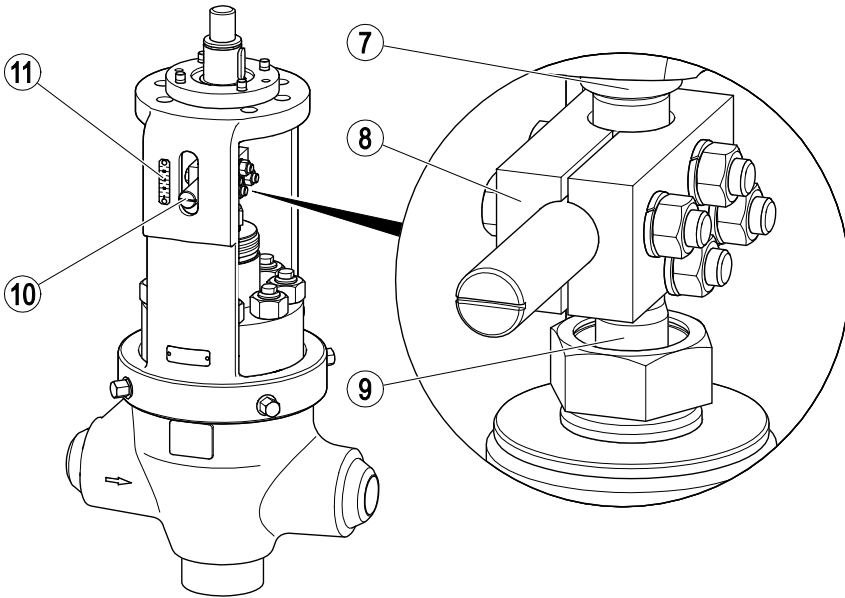

| No. | Designation                    |
|-----|--------------------------------|
| 7   | Spindle                        |
| 8   | Coupling                       |
| 9   | Stem (installed in upper part) |

| No. | Designation                              |
|-----|------------------------------------------|
| 10  | Indicator for scale markings on coupling |
| 11  | Scale                                    |

The stuffing box seal consists of the following items:

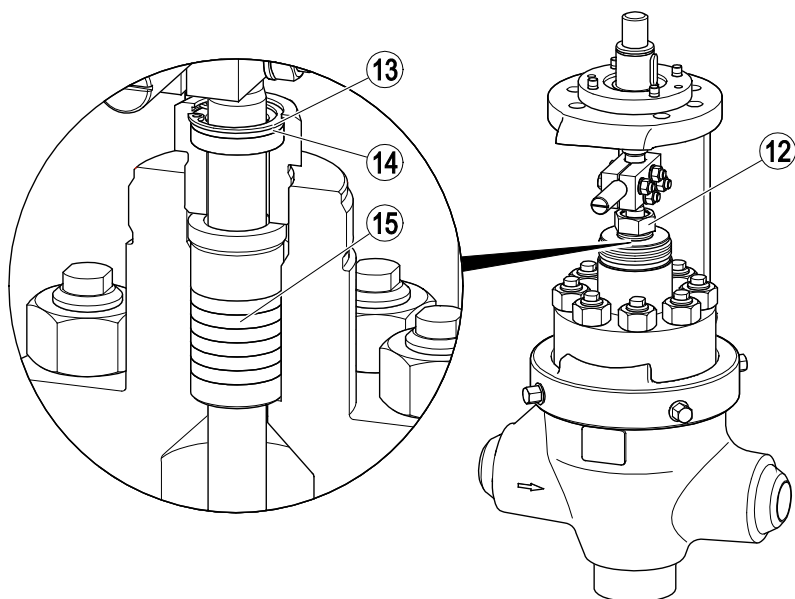

| No. | Designation    |
|-----|----------------|
| 12  | Screwed union  |
| 13  | Retaining ring |

| No. | Designation   |
|-----|---------------|
| 14  | Support disk  |
| 15  | Gland packing |

The following items are fitted inside the equipment:

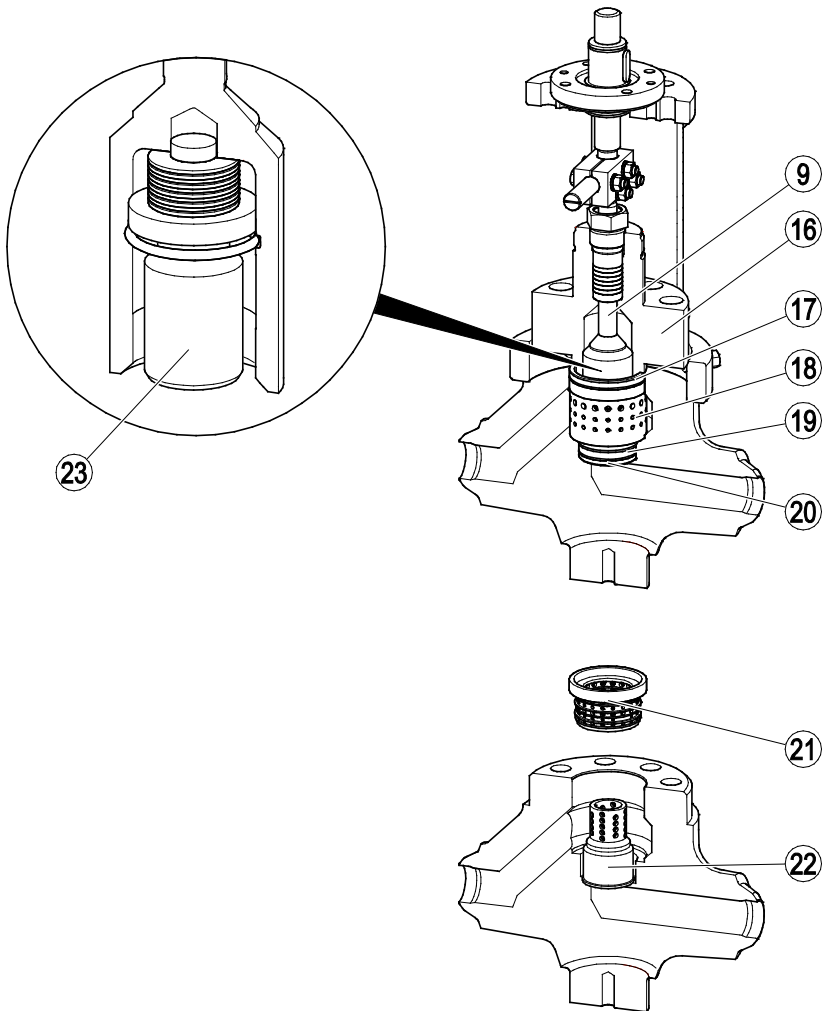

| No. | Designation       |
|-----|-------------------|
| 9   | Stem              |
| 16  | Upper part        |
| 17  | Upper main gasket |
| 18  | Pressure element  |
| 19  | Lower main gasket |

| No. | Designation  |
|-----|--------------|
| 20  | Ring         |
| 21  | Throttle     |
| 22  | Seat bushing |
| 23  | Valve plug   |

Equipment with spindle bearing features a bonnet that is provided with a grease nipple.

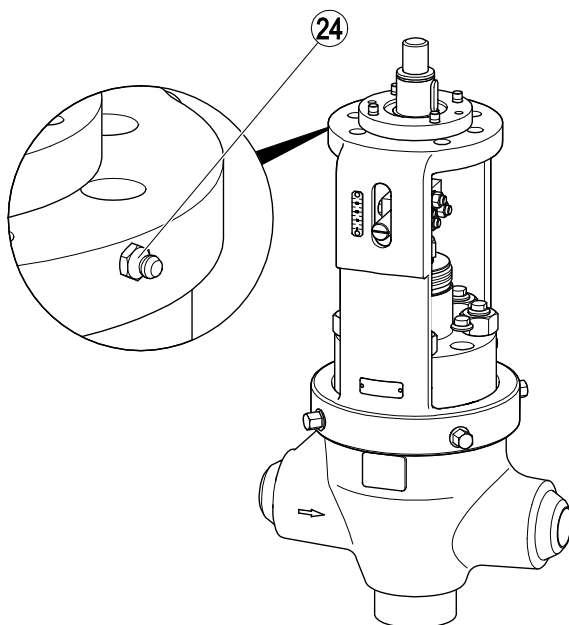

| <b>No.</b> | <b>Designation</b>                                                          |
|------------|-----------------------------------------------------------------------------|
| 24         | Grease nipple (only on actuator with handwheel or electric rotary actuator) |

## **Name plate**

The following items are indicated on the name plate:

- ▶ Manufacturer
- ▶ Type designation
- ▶ Design
- ▶ Nominal size
- ▶ Pressure rating
- ▶ Max. service temperature
- ▶ Max. service pressure
- ▶ Max. admissible differential pressure
- ▶ Flow characteristic
- ▶ CE marking
- ▶ Serial number

The following items are indicated on the equipment body:

- ▶ Material
- ▶ Identification marking of material testing
- ▶ Batch code
- ▶ Direction of flow
- ▶ Manufacturing date (quarter/year)

## **Application of European Directives**

### **Pressure Equipment Directive**

The equipment conforms to this Directive (see "Declaration of Incorporation" section) and can be used for the following media:

- ▶ Fluids of group 2

### **ATEX Directive**

The equipment has classification: CE Ex II 2G/D c X.

For use in potentially explosive atmospheres in zones (surrounding atmosphere to Directive 1999/92/EC) 1, 2, 21 and 22, please read and observe the following information:

The sign "X" in the Ex label signifies that operation at an excessive surface temperature caused by the medium must be avoided. The equipment itself does not generate additional surface temperatures.

Once installed, static electricity may arise between the equipment and the connected system. During use in potentially explosive atmospheres, the discharge or prevention of possible electrostatic charging is the responsibility of the manufacturer or owner of the system. If there is a possibility that medium might escape, e.g. via actuating devices or leaks in screwed couplings, the manufacturer or owner of the system must take this into consideration when dividing the area into zones.

The equipment classification and Declaration of Conformity do not apply to any electric, hydraulic or pneumatic drive that may be installed.

If using the equipment with a drive, the category of the drive may have an adverse effect on the equipment category 2G/D.

- Please read and observe the relevant information in the drive manufacturer's documentation.

## Task and function

### Purpose

The equipment is designed to reduce pressure in pipes through which the following fluids flow:

- ▶ water
- ▶ steam
- ▶ condensed water

In addition the equipment can control the flowrate and the fluid level. The equipment can stop the fluid flow completely, effecting a pipe seal to attain bubble-tight shut off.

The tandem seat reduces the flow velocity at the seating surface during opening and closing, thereby minimizing the wear on the seating surfaces.

### Function

The equipment features a system of flash chambers where the differential pressure is reduced in stages and the flow is split up into many partial flows. This decreases the noise level during operation and extends the service life of the equipment thanks to reduced wear.

The equipment is fitted with an externally actuated stem. During the opening process the stem controls the fluid flow by successively opening a series of flash chambers.

When the stem is in the closed position the fluid flow is completely stopped and bubble-tight closure is ensured.

The tandem seat consists of a primary and a secondary seat for double shut-off. When the equipment is closed the stem (9) and plug (23) are in the lowest position.

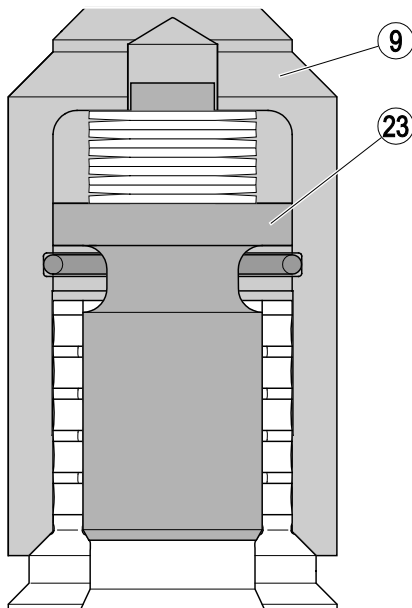

During the opening process first only the stem lifts off. As a result of the reduced load the disc springs (25) decompress.

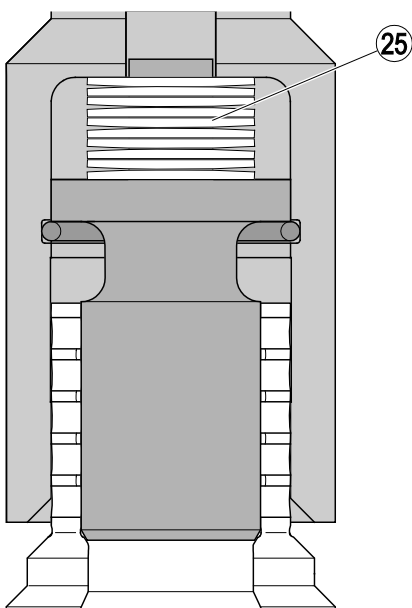

Then the plug is lifted off its seat by the retaining ring (26). The equipment is now open.

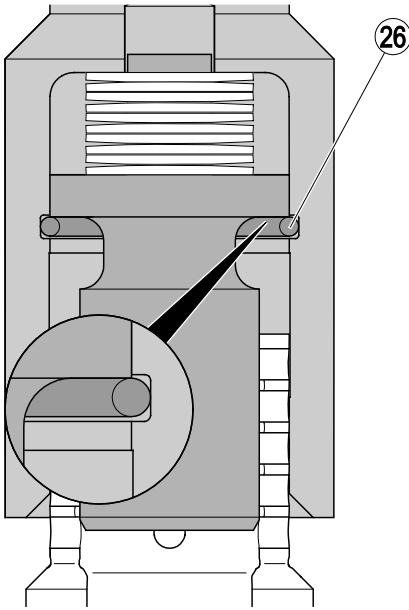

## Storing the equipment

- Please observe the following items when storing the equipment:
  - Make sure that the equipment is completely disconnected.
  - Before storage make sure that the equipment is dry and free from any fluid residues.
  - The equipment must be protected by its packaging. The packaging must protect the equipment from moisture and mechanical damage.
  - The equipment must be stored in a horizontal position.
  - Make sure that the stem of the equipment is moved at least every two months in order to avoid that the packing rings get stuck.



### CAUTION

There is a risk of getting crushed by the spindle.

- Wear sturdy leather gloves when working on the spindle or stem.
- Make sure that no persons are in the area of the spindle or stem.
- Move the spindle slowly.

## Storing and transporting the equipment

### ***Attention!***

Equipment can be damaged if stored or transported improperly.

- Close all openings with the sealing plugs or covers supplied with the equipment or use similar sealing covers.
- Protect the equipment against moisture and corrosive atmospheres.
- Please contact the manufacturer if the specified transport and/or storage requirements cannot be met.

- Follow all instructions given in the installation & operating manual of the actuator.
- Make sure that all these requirements are always met when storing the equipment.
- Please contact the manufacturer if you cannot comply with the recommended storage conditions.



## Transporting the equipment

---



### DANGER

Risk of bruises if the equipment or component parts fall down.

- Always wear protective gear when working on the equipment.
- Use suitable lifting gear when moving or lifting the equipment and/or component parts.
- Make sure that the equipment cannot topple over.
- To lift the equipment use only the valve body or the bonnet.
- Make sure that nobody is standing below the lifted equipment.

---

The protective gear must comprise at least the following:

- ◆ Safety helmet to EN 397
- ◆ Safety footwear to EN ISO 20345
- ◆ Protective leather gloves to EN 388

For more information on suitable safety clothing and safety gear refer to the safety data sheet of the fluid in question.

The lifting gear must be of sufficient strength for the equipment including the actuator.

For more information on the weight of the equipment see the attached documents. For more information on the weight of the actuator see the documents provided by the actuator manufacturer.

For more information on lifting points and the centres of mass see the attached documents.

- Carefully clean the equipment before transportation.
- Meet the requirements for storage also when transporting the equipment.
- Prior to transport seal off connections with sealing plugs.



If you do not have the sealing plugs supplied with the equipment use appropriate seal caps to seal off the connections.

- For short distances (only a few metres) you can transport the equipment unpacked.
- When transporting the equipment over larger distances use the original packaging.
- If you do not have the original packaging use a box that protects the equipment adequately against corrosion and physical damage.

## Mounting and connecting the equipment



### DANGER

Risk of bruises if the equipment or component parts fall down.

- Always wear protective gear when working on the equipment.
- Use suitable lifting gear when moving or lifting the equipment and/or component parts.
- Make sure that the equipment cannot topple over.
- To lift the equipment use only the valve body or the bonnet.
- Make sure that nobody is standing below the lifted equipment.

The protective gear must comprise at least the following:

- ▶ Safety helmet to EN 397
- ▶ Safety footwear to EN ISO 20345
- ▶ Protective leather gloves to EN 388

For more information on suitable safety clothing and safety gear refer to the safety data sheet of the fluid in question.

The lifting gear must be of sufficient strength for the equipment including the actuator.

For more information on the weight of the equipment see the attached documents. For more information on the weight of the actuator see the documents provided by the actuator manufacturer.

## Preparing installation

- Remove the transport packaging.
- Check the equipment for transport damage.
- If you detect any transport damage, please contact the manufacturer.

When supplied by the factory, the connections may be sealed off with sealing plugs.

- Remove sealing plugs before mounting the equipment.
- Keep the sealing plugs and the packing for further use.



### DANGER

Personnel working on pipes are exposed to safety risks and may suffer severe injuries, poisoning or even loss of life.

- Make sure that no hot or hazardous fluid is in the equipment or the pipes.
- Make sure that the pipes upstream and downstream of the equipment are depressurised.
- Make sure that the installation is switched off and protected against unauthorised or unintended activation.
- Make sure that the equipment and the pipes have cooled down to room temperatures.
- Wear protective clothing that is suitable for the fluid and, if necessary, wear protective gear.

For more information on suitable protective clothing and safety gear refer to the safety data sheet of the fluid in question.

- Drain pipes until they are empty.
- Switch the installation off and protect it against unauthorised or unintended re-activation.

## Connecting the equipment

---



### **DANGER**

Incorrectly connected equipment can result in accidents with extremely severe injuries or death.

- Make sure that only specialist personnel connect the equipment to the pipe.
- Make sure that the direction of flow in the pipe matches the flow direction arrow on the equipment.
- Make sure that the connected pipe does not subject the body to any stress (forces or torques) during installation and operation.

---

Specialist personnel must have knowledge and experience of the type of pipe connection used.



An arrow indicating the flow direction is provided on both sides of the inlet of the valve body.

---

### **Attention!**

Equipment will be damaged if the support is undersized or in the wrong place.

- Mount the support to the pipes next to the equipment.
  - Make sure that the supports are strong enough to hold the weight of the equipment and to withstand the forces that occur during operation.
  - Contact the manufacturer if you want to mount the supports directly to the equipment.
- 



The equipment is designed for installation with the stem in vertical position and the actuator mounted on top.

Other installation positions are possible.

- Contact the manufacturer if you want to mount the equipment in a different position of installation.
- Mount the equipment in the desired installation position.
- Make sure that the equipment is supported by the pipes.



If the supports can only be attached directly to the equipment ask the manufacturer for more information on possible positions for the supports.

- Connect the end connections of the equipment properly to the pipes.

Some materials require a subsequent heat treatment of the welds after the equipment has been welded in place. If you want to perform a heat treatment please observe the following notes:



You do not have to remove the internals of the equipment in order to perform the heat treatment.

---

### **Attention!**

The equipment might get damaged.

- Make sure that only qualified personnel carries out the heat treatment.
  - Before starting the heat treatment make sure that the equipment is not insulated.
- 

Specialist personnel must be highly qualified and fully experienced in making welded joints with the type of material used. For information on the materials of the equipment see the nameplate on the equipment.

- Make sure that the valve is at its middle position, i. e. half stroke.

- Make sure that only qualified personnel carries out the heat treatment.
- After the heat treatment you may insulate the equipment if necessary.



## DANGER

Incorrectly connected equipment can cause fatal accidents or severe injuries.

- Make sure that only qualified skilled personnel connect the actuator to the power supply.
- Follow all instructions given by the actuator manufacturer.

---

Specialist personnel must be highly qualified and fully experienced in connecting the power supply in question.

- Connect the actuator properly with the mechanical connection of the equipment.



For more details on how to connect the actuator with the stem and how to mount the mechanical connection see page 38.

- Connect the actuator properly to its power supply.

## Checking the function

- Make sure that the equipment is safely mounted and that all connections are made correctly.



To remove residues from the pipes and the equipment after installation purge the pipes with the fluid to be used. For more information see chapter *"Rinse the equipment"* on page 24.



## CAUTION

There is a risk of getting crushed by the spindle.

- Wear sturdy leather gloves when working on the spindle or stem.
  - Make sure that no persons are in the area of the spindle or stem.
  - Move the spindle slowly.
- 
- Carry out a performance test to check the functions of the equipment.
- The stem must perform at least one full valve stroke.
- Change, if necessary, the actuator settings as indicated in the operating manual of the actuator.

## Operating the equipment

Do not work on the equipment while it is operating.



### DANGER

Risk of bruises when working on the equipment during operation.

- Switch off the equipment if you have to work close to any moving equipment parts.
- Make sure that the equipment cannot be switched on inadvertently.

The stem of the equipment is moved according to the actuator setting.

- If you want to change the settings please follow the instructions given in the operating manual for the actuator.

### *Attention!*

Damage to the equipment or malfunctions may occur if the stem is not moved for a longer period of time.

- Make sure that the stem performs at least one full stroke every two months.

## After operation



### DANGER

If the equipment is used in contaminated areas there is a risk of severe injuries or death caused by harmful substances in or on the equipment.

- Only qualified personnel are allowed to perform work on contaminated equipment.
- Always wear the protective clothing prescribed for contaminated areas when working on the equipment.
- Make sure that the equipment is completely decontaminated before carrying out any service work.
- Follow the pertinent instructions for handling the hazardous substances in question.



### DANGER

Personnel working on pipes are exposed to safety risks and may suffer severe injuries, poisoning or even loss of life.

- Make sure that no hot or hazardous fluid is in the equipment or the pipes.
- Make sure that the pipes upstream and downstream of the equipment are depressurised.
- Make sure that the installation is switched off and protected against unauthorised or unintended activation.
- Make sure that the equipment and the pipes have cooled down to room temperatures.
- Wear protective clothing that is suitable for the fluid and, if necessary, wear protective gear.

For more information on suitable protective clothing and safety gear refer to the safety data sheet of the fluid in question.

---



## **DANGER**

Risk of bruises when working on the equipment during operation.

- Switch off the equipment if you have to work close to any moving equipment parts.
  - Make sure that the equipment cannot be switched on inadvertently.
- 
- 

## ***Attention!***

Damage to the equipment due to improper maintenance work.

- Make sure that only qualified personnel performs maintenance work.
- 

A qualified person must be acquainted with and experienced in the following:

- ▶ Working on pressure equipment
- ▶ Lifting loads
- ▶ Assembling and disassembling the equipment
- ▶ The qualified personnel must observe and follow the instructions given in this operating manual and in the applicable documents.

## Maintaining the equipment

### Maintenance schedule

| Interval  | Component                                                                                                                                                 | Activity                                                                                                                                                                                      |
|-----------|-----------------------------------------------------------------------------------------------------------------------------------------------------------|-----------------------------------------------------------------------------------------------------------------------------------------------------------------------------------------------|
| 2 months  | Stem                                                                                                                                                      | Move stem by at least one complete stroke.                                                                                                                                                    |
| 3 months  | Stuffing box seal                                                                                                                                         | Visually inspect to ensure tightness.<br>Retighten a leaky stuffing box, replace if necessary.                                                                                                |
|           | <ul style="list-style-type: none"> <li>▶ Connections</li> <li>▶ Body gasket</li> <li>▶ Positioning of spindle in gland seal</li> <li>▶ Spindle</li> </ul> | Visually inspect the following points: <ul style="list-style-type: none"> <li>▶ Tightness</li> <li>▶ Cleanliness</li> <li>▶ Wear</li> </ul> Replace leaky or worn components.<br>Remove dirt. |
|           | <ul style="list-style-type: none"> <li>▶ Stem</li> <li>▶ Seat ring</li> </ul>                                                                             | Check that the equipment closes correctly when the stem is in closed position by measuring the temperature.<br>Replace leaky or worn components.                                              |
|           | Spindle bearing                                                                                                                                           | Grease with the recommended grease (see next section) and a lint-free cloth.                                                                                                                  |
|           | Lubricating nipples on spindle bearing (equipment with rotating motor)                                                                                    | Apply the recommended grease (see next section).                                                                                                                                              |
| 12 months | Secure actuator fastening                                                                                                                                 | Check that screws and bolts are secure.<br>Tighten loose screws to the specified torque.<br>You can find information on the required torques in the actuator installation instructions.       |
| 36 months | Overall equipment                                                                                                                                         | Check condition of inner parts.<br>Check condition of spindle.<br>Replace faulty or worn components.<br>Replace main gaskets before assembly.                                                 |

## Lubricating the equipment

---

### **Attention!**

Equipment may be damaged if unsuitable lubricant is used.

- Use only specified lubricants.

- Use only lithium-saponified grease, penetration grade 2, with MoS<sub>2</sub> additive.

The following lubricants are recommended for lubricating the equipment:

- ▶ WINIX 5000
- Lubricate all moving parts of the equipment every three months.

## Removing dirt deposits

- To remove dirt deposits rinse the equipment with fresh water and wipe it with a clean, lint-free cloth.
- To remove any persistent residues use a cleaning agent that is suitable for the material and carefully wipe the equipment with a clean, lint-free cloth.

For information on the materials of the equipment see section *Disposing of the equipment*.

- For more information on material options please contact the manufacturer.

## Replacing component parts

To replace a component part proceed as follows:

- Disassemble the equipment as described from page 26 onwards.
- Replace the component part with an original spare part from the manufacturer.

For details on how to order spare parts refer to the parts list.

- The two main gaskets of the equipment must be replaced in any case.
- Re-assemble the equipment as described from page 38 onwards.

## Rinse the equipment

Rinse the equipment in order to remove any dirt particles or fluid residues inside the equipment.



### **DANGER**

Personnel working on pipes are exposed to safety risks and may suffer severe injuries, poisoning or even loss of life.

- Make sure that no hot or hazardous fluid is in the equipment or the pipes.
- Make sure that the pipes upstream and downstream of the equipment are depressurised.
- Make sure that the installation is switched off and protected against unauthorised or unintended activation.
- Make sure that the equipment and the pipes have cooled down to room temperatures.
- Wear protective clothing that is suitable for the fluid and, if necessary, wear protective gear.

For more information on suitable protective clothing and safety gear refer to the safety data sheet of the fluid in question.



## Preparing equipment for rinsing

Remove all parts from the body before rinsing the equipment.

- Disassemble the equipment as described from page 26 onwards.
- Put a blind flange onto the body.

Contact the manufacturer to obtain information on suitable blind flanges.

- Fasten the blind flange with a gasket sealing and additional distance sleeves, the stud bolts and hexagon nuts for the upper part.
- Tighten the hexagon nuts with the same torque that is specified for tightening the upper part.

## Rinsing equipment and pipes

You can rinse the equipment with the same fluid that is used during normal operation. You can also use a special cleaning agent.



### **DANGER**

Personnel working on pipes are exposed to safety risks and may suffer severe injuries, poisoning or even loss of life.

- Make sure that no hot or hazardous fluid is in the equipment or the pipes.
- Make sure that the pipes upstream and downstream of the equipment are depressurised.
- Make sure that the installation is switched off and protected against unauthorised or unintended activation.
- Make sure that the equipment and the pipes have cooled down to room temperatures.
- Wear protective clothing that is suitable for the fluid and, if necessary, wear protective gear.

For more information on suitable protective clothing and safety gear refer to the safety data sheet of the fluid in question.

## **Attention!**

Equipment may be damaged by unsuitable cleaning fluid.

- Rinse the pipe with the same fluid that is used during normal operation.
- Make sure that the cleaning fluid does not damage the equipment material if you use a different fluid for cleaning than the normal operating fluid.
- Make sure that the cleaning fluid does not come into contact with the fluid used during normal operation.

For information on the materials of the equipment see section *Disposing of the equipment*.

- For more information on material options please contact the manufacturer.
- Switch on the installation and rinse the pipes.
- Check connections for leaks.
- After rinsing keep the installation switched on until the pipes are completely empty.
- Switch the installation off and protect it against unauthorised or unintended re-activation.

## **Mounting parts after rinsing**

After rinsing re-install the removed parts to render the equipment operational.

- Undo the hexagon nuts of the blind flange.
- Remove the distance sleeves and the blind flange.
- Keep the distance sleeves and the blind flange for further use.
- Re-assemble the equipment as described from page 38 onwards.

## Disassembling the equipment

You have to disassemble the equipment if you want to

- ▶ rinse the pipes and the equipment
- ▶ service component parts
- ▶ replace or exchange component parts.



If you exchange component parts you can use the equipment for different application conditions.

For this purpose you do not have to remove the equipment from the installation.

- ▶ Ask the manufacturer for information on possible retrofitting modifications for your equipment.



### CAUTION

Sharp edges on component parts can cause cuts.

- ▶ Wear industrial gloves when servicing equipment parts.

To dismantle and re-assemble the equipment use the following tools:

- ▶ Flat screwdriver for slotted screws with thin (3 - 4 mm) blade
- ▶ Hooke made from wire with approx. 2 mm point
- ▶ Torque spanner (US: wrench) 20–300 Nm
- ▶ Open-end spanner



The size of the tools depends on the equipment type.

- ▶ Use only tools of suitable size.

To remove and mount internal parts you must use the "Tool kit for removing internals" for valves of type ZK 313. To order the tool kit please state the following stock code number:

- ▶ 368220

The document no. 4-ZK 428 comes with the tool kit. It describes the content and application of the kit in detail.

- ▶ If you need more information on the tool kit please refer to the manufacturer.

## Preparing the equipment for disassembly



### DANGER

Personnel working on pipes are exposed to safety risks and may suffer severe injuries, poisoning or even loss of life.

- ▶ Make sure that no hot or hazardous fluid is in the equipment or the pipes.
- ▶ Make sure that the pipes upstream and downstream of the equipment are depressurised.
- ▶ Make sure that the installation is switched off and protected against unauthorised or unintended activation.
- ▶ Make sure that the equipment and the pipes have cooled down to room temperatures.
- ▶ Wear protective clothing that is suitable for the fluid and, if necessary, wear protective gear.

For more information on suitable protective clothing and safety gear refer to the safety data sheet of the fluid in question.

- ▶ Shut off the pipes upstream and downstream of the equipment.



## DANGER

Risk of bruises if the equipment or component parts fall down.

- Always wear protective gear when working on the equipment.
- Use suitable lifting gear when moving or lifting the equipment and/or component parts.
- Make sure that the equipment cannot topple over.
- To lift the equipment use only the valve body or the bonnet.
- Make sure that nobody is standing below the lifted equipment.

The protective gear must comprise at least the following:

- ◆ Safety helmet to EN 397
- ◆ Safety footwear to EN ISO 20345
- ◆ Protective leather gloves to EN 388

For more information on suitable safety clothing and safety gear refer to the safety data sheet of the fluid in question.

The lifting gear must be of sufficient strength for the equipment including the actuator.

For more information on the weight of the equipment see the attached documents. For more information on the weight of the actuator see the documents provided by the actuator manufacturer.

Connect the lifting gear to the equipment or part that you want to lift.

- For this purpose use a noose strap of sufficiently sturdy material.
- Attach the noose strap to the lifting points or a flange.



The space required for disassembling and re-assembling the equipment depends on the optional extras and the type of actuator.

For more information on the required service space see the attached drawings.

## ***Attention!***

The equipment or component parts may be damaged if it is disassembled or re-assembled in the wrong order.

- Always follow the sequence of activities described in the following sections.

## ***Attention!***

Equipment may be damaged if unsuitable tools are used.

- Use only tools that are suitable for the size of the equipment components.
- If a tools list is supplied with the equipment, use only tools specified in this list.
- For more information on suitable tools please contact the manufacturer.

## **Removing actuator parts**

If the equipment is fitted with an actuator first remove the actuator.

- Disconnect the actuator as described in the operating manual for the actuator.
- Remove the actuator as described in the operating manual for the actuator.

You can now remove the mechanical connection for the actuator from the equipment.

For equipment with an electrical rotating motor, you must remove the spindle bearing. You do not have to remove the spindle from the bearing to do this.

- Loosen the hexagon nuts (27) on the coupling.
- Remove the hexagon-head cap screws (28) and the locking washers (29).
- Remove the two halves of the coupling (8) and the pointer (10) for the scale marking.

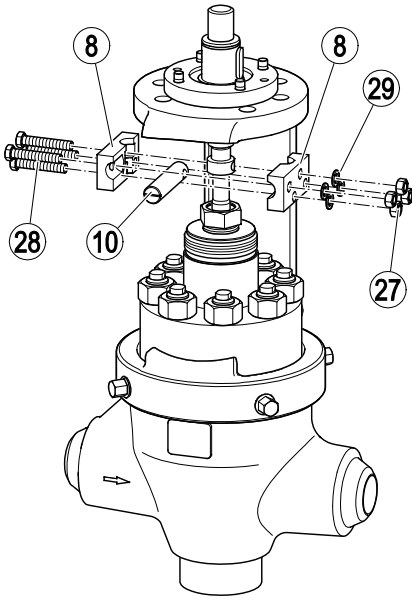

You can now remove the mechanical connection for the actuator.

For equipment with an electrical rotating motor, you must remove the spindle bearing and spindle.

- Loosen the nuts (32).
- Remove the fixing studs (30) and the locking washers (31).

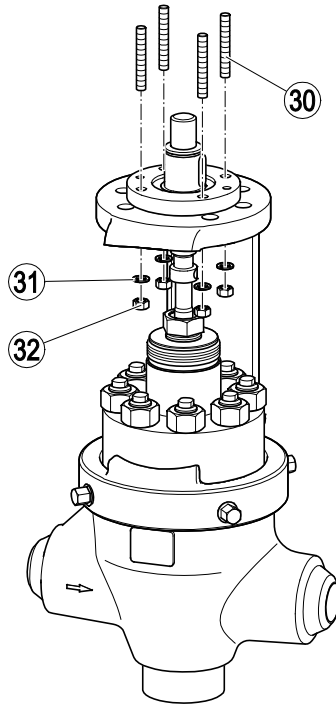

- Remove the two hexagon head screws (34).



The following drawing shows the equipment with actuator bearing for an electric rotary actuator. Here the mechanical connection for the actuator is designed as a spindle bearing (33). The spindle (7) is connected with the spindle bearing and can be removed together with it.

- Remove the mechanical connection for the actuator from the equipment.

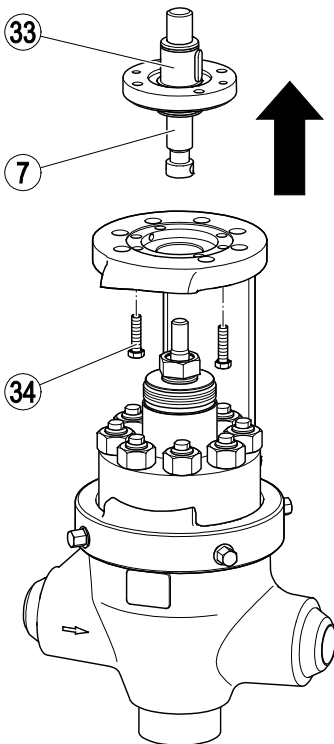

- Unscrew the spindle out of the bearing if necessary.

## Removing the bonnet



The attachment of the bonnet to the body depends on the type of actuator. Valves with pneumatic actuator feature a groove nut with which the bonnet is fixed. All other types of actuator use grub screws for attaching the bonnet to the valve body. The following two sections describe the mounting options in more detail.

### Removing the standard bonnet

- Remove the grub screws (35).
- Connect the noose strap of a sufficiently strong lifting gear to the bonnet flange.
- Lift off the bonnet (2).

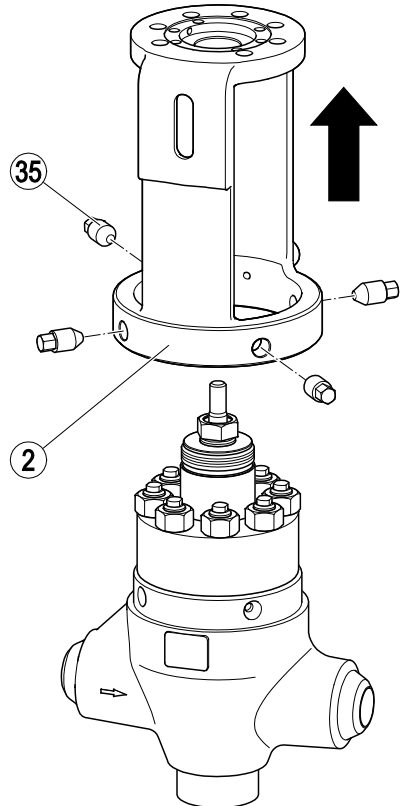

## Removing the bonnet of equipment with pneumatic actuator



If the equipment is fitted with a pneumatic actuator, the bonnet (here called yoke) is an elemental part of the actuator.

In this type of equipment the bonnet is called "yoke".



In order to distinguish the yoke more clearly from the standard bonnet, the following drawing shows the actuator. The actuator must be removed before the bonnet can be dismantled.

- Do not dismantle the yoke before all actuator parts including the coupling have been removed.
- For this purpose proceed as described in section „Removing actuator parts“ on page 27 beschrieben.

- Unscrew the screw-in adapter (38) from the stem (1.).
- Unscrew the groove nut (36) (2.).
- Lift off the yoke (2) together with the actuator (3.).
- Take off the distance ring (37).

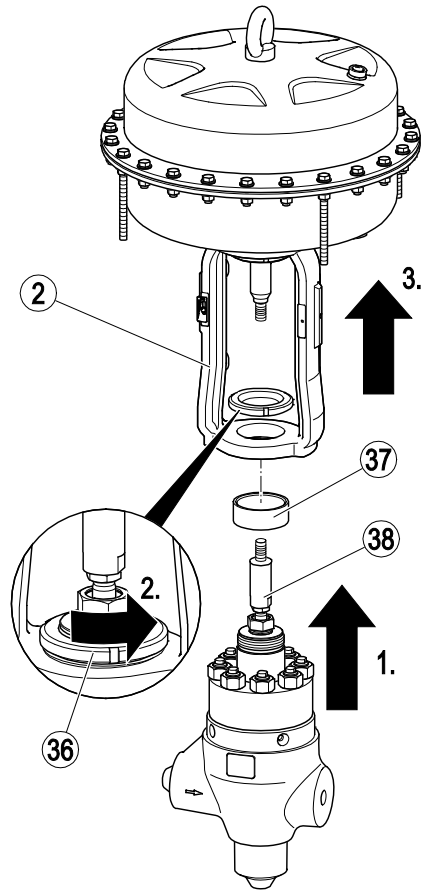

## Removing the upper part

The following components are removed together with the upper part.

- ▶ Stem (9) with plug
- ▶ Stuffing-box packing with screwed union (12)
- Unscrew the hexagon nuts (39) on the upper part (1.)
- Loosen the screwed-union (12) until you can move the stem (2.).
- Slowly pull the stem (9) upwards until it hits the stop (3.) and hold the stem in this position.
- Lift the upper part (16) off the stud bolts (40) (4.).
- Protect the dismantled parts from damage and dirt.

The tool kit for removing the internals can only be used if the stud bolts (40) are attached to the body and the hexagon nuts (39) are screwed on.

- Screw the hexagon nuts (39) handtight onto the stud bolts (40).

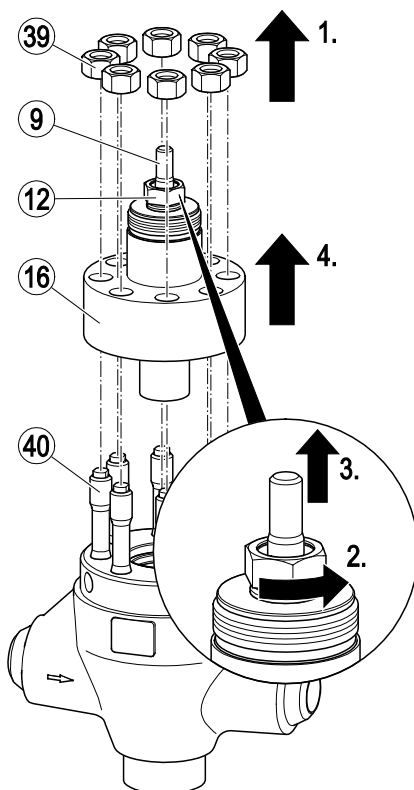

## Removing inner parts

To remove and mount internal parts you must use the "Tool kit for removing internals for valves of type ZK 313".

The tool kit consists of the following parts:

- ▶ Extraction devices for different types of equipment
- ▶ Yoke
- ▶ Hexagon nut
- ▶ Spindle for extraction device

**i** By using the tool kit you can remove all internals together.

The following components are removed together with the seat bushing:

- ▶ Upper main gasket (17)
- ▶ Pressure-bearing element
- ▶ Lower main gasket (19)
- ▶ Ring (20)
- ▶ Throttle unit (21)
- ▶ Seat bushing (22)

**i** For the sake of simplicity the following drawing does not show the nuts on the stud bolts.

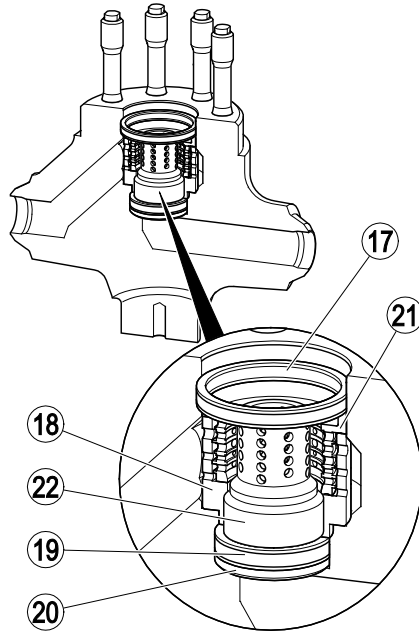

**i** The tool kit contains different extraction devices for the various equipment types.

- Choose the extraction device according to the specification in the document "*Tool kit for removing/mounting internals for valves of type ZK 313*" (4-ZK 428).

In this document you will also find information on how to remove internals from hammer-forged bodies.



- Put the extraction device (41) together with the adapter (42) into the seat bushing.

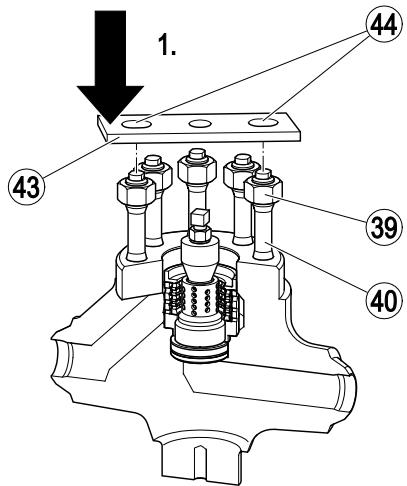
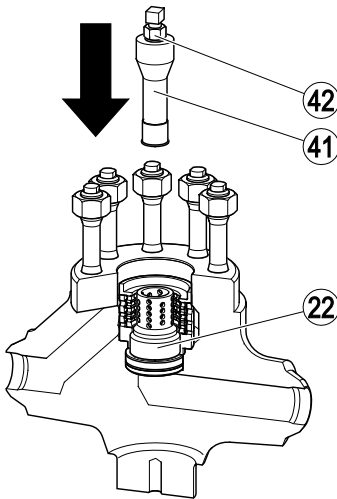

- Use a spanner (US: wrench) to retain the extraction device.
- Turn the adapter clockwise until the extraction device is securely seated.

The extraction device is now firmly clamped in the seat bushing. You can now take the internals out of the body by means of the extraction device.

## Attention

Damage may occur if the yoke slips off during dismantling.

- Make sure that the yoke with the seating faces is correctly positioned on the stud bolts and nuts.
- 
- Put the yoke (43) onto the stud bolts (40) (1.).
  - Make sure that the seating faces (44) at the yoke rest on the stud bolts and nuts.

- Insert the spindle (45) through the bore in the yoke (43) (2.).
- Screw together the spindle and the extraction device (41) (3.)
- Screw the hexagon nut (46) handtight onto the spindle (4).)
- To lift the seat bushing and the other internals off the body, slowly fasten the hexagon nut.

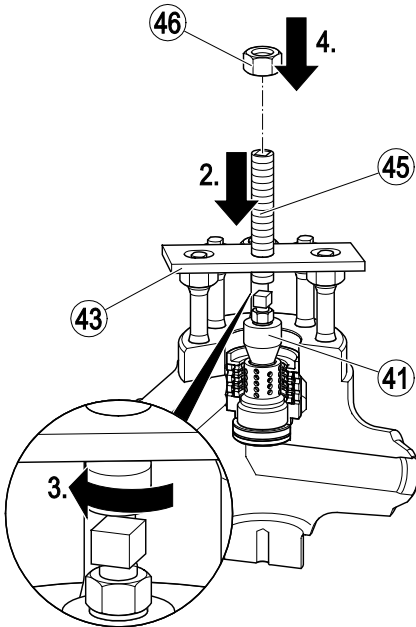

## Removing the gland seal



You only have to dismount the stuffing box if you want to exchange parts of the stuffing-box packing.

To dismantle the stem and the plug you do not have to remove the stuffing box.

- To remove the stem loosen the stuffing box.

---

### **Attention!**

The packing rings may get damaged.

- Make sure you do not damage the packing rings during installation and removal.
- When installing and removing the packing rings never use force. Make sure that the packing rings are correctly positioned and not skewed.

- 
- Take the screwed union (12) out of the upper part.
  - Take the retaining ring (13) out of the screwed union.
  - Take the support disk (14) out of the screwed union.
  - Take the packing ring (15) out of the screwed union.

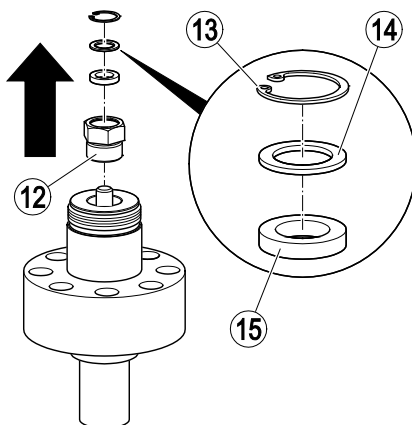

- Take the packing gland (47) out of the upper part.
- Take the packing rings (15) of the packing gland out of the upper part.

**i** The number of pure graphite rings depends on the size of the equipment.

- Make a note of the type and order of the individual packing rings for their later re-installation.

- Take the stuffing box ring (48) off the upper part.

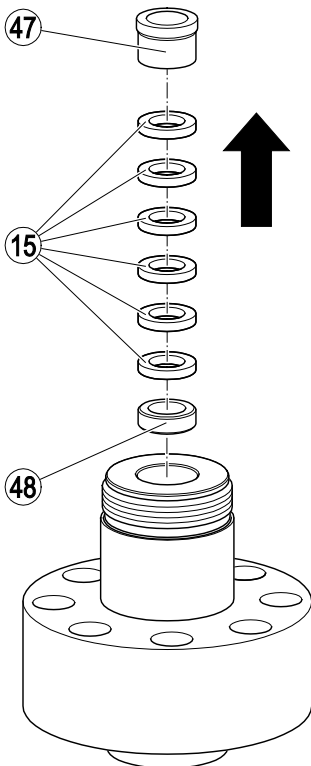

## Removing the plug and disc springs

The retaining ring connects the plug with the stem. The retaining ring can be accessed via the gap between the plug and the stem.

**i** To remove the retaining ring use a screwdriver for slotted screws with a small blade and a hook made from strong wire.

The blade width of the screwdriver should be approx. 3–4 mm.

The width of hook tip should be approx. 2 mm.

To clamp the stem you need a clamping device with clamping jaws with rubber coating.

- For more details please contact the manufacturer.



## CAUTION

Operating personnel may get injured if the disc springs are decompressed in an uncontrolled manner.

- Always wear sturdy work gloves and safety goggles when working on the stem and plug.
- Detach or attach the stem and plug only if the stem is held in position by means of a sturdy clamping device.
- Use a suitable device to force the plug into the stem.

It must be possible to lock the device in place. A suitable device is, for example, a pillar-type drilling machine.

## Attention

Damage may occur if an unsuitable clamping device is used.

- Use only a clamping device with clamping jaws with rubber coating.
- For more details please contact the manufacturer.

- Clamp the stem (9) in the clamping device.
- Force the plug (23) into the stem.
- Use a suitable device to hold the plug in this position.

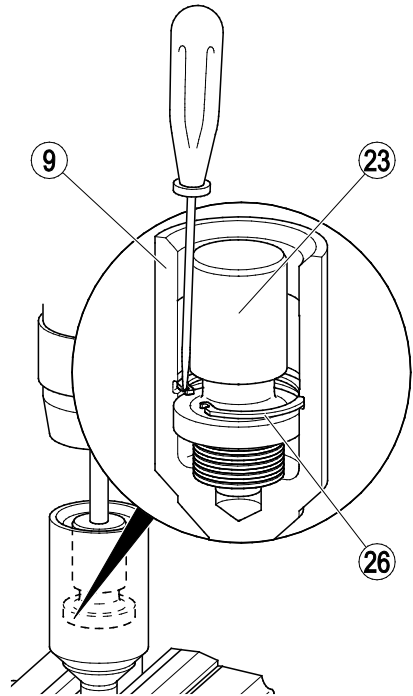
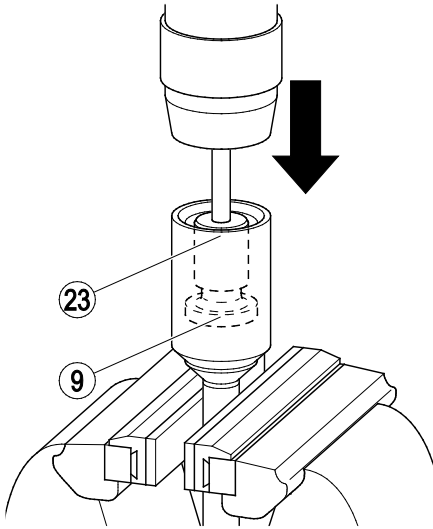

- Use a screwdriver to lever the retaining ring (26) out of the groove in the stem (9).
- Put the point of the wire hook under the retaining ring.
- Lift the hook to take the retaining ring out of gap between the stem (9) and the plug (23).



## CAUTION

Operating personnel may get injured if the disc springs are decompressed in an uncontrolled manner.

- Always wear sturdy work gloves and safety goggles when working on the stem and plug.
- Detach or attach the stem and plug only if the stem is held in position by means of a sturdy clamping device.
- Use a suitable device to force the plug into the stem.

It must be possible to lock the device in place. A suitable device is, for example, a pillar-type drilling machine.

- Remove the device slowly and carefully.
- Take the plug (23) off the stem.
- Lift the stem out of the clamping device.
- Take the disc springs (25) out of the plug.

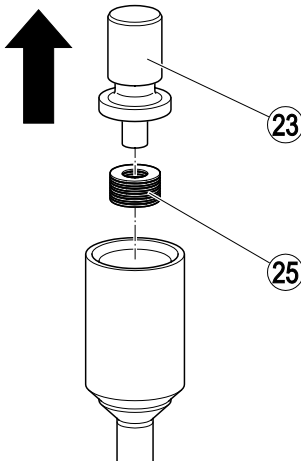

## Assembling the equipment

### Work prior to re-installation



## CAUTION

Sharp edges on component parts can cause cuts.

- Wear industrial gloves when servicing equipment parts.
- Clean all component parts before re-installing them.
- Make sure that the sealing surfaces of the stem and seat are correctly surfaced in relation to one another.

## Attention!

Equipment may leak if the gaskets are damaged.

- Always insert new main gaskets when assembling the equipment.
- Check all gaskets, seals and packing rings before installing them.
- Replace any damaged gasket, seal or packing ring.
- Check all component parts.
- Replace the two main gaskets and any damaged components.

---

### **Attention!**

Equipment may not work properly or get damaged if parts are tilted or skewed when installed.

- Use suitable lifting gear to mount the component parts.
- Do not tilt or skew the component parts during installation.
- During installation make sure that the component parts are not damaged by physical shocks.

---

The required bearing capacity of the lifting gear depends on the equipment type. Contact the manufacturer for more information on the weights of the individual parts.

### **Installing the plug and disc springs**

- Insert the disc springs (25) in the same position they were when the plug (23) was removed (1.).
- Insert the plug with the disc springs into the stem (2.).

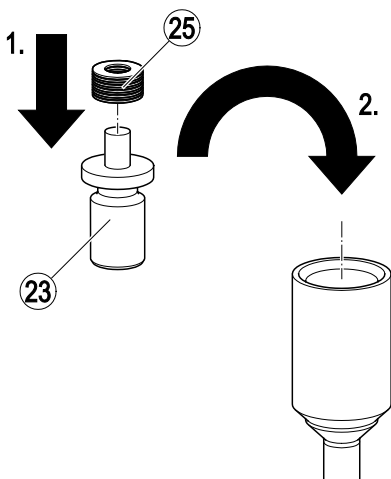

### **CAUTION**

Operating personnel may get injured if the disc springs are decompressed in an uncontrolled manner.

- Always wear sturdy work gloves and safety goggles when working on the stem and plug.
- Detach or attach the stem and plug only if the stem is held in position by means of a sturdy clamping device.
- Use a suitable device to force the plug into the stem.

---

It must be possible to lock the device in place. A suitable device is, for example, a pillar-type drilling machine.

---

### **Attention**

Damage may occur if an unsuitable clamping device is used.

- Use only a clamping device with clamping jaws with rubber coating.
  - For more details please contact the manufacturer.
-

- Clamp the stem (9) into the jaws of the clamping device.
- Use a suitable device to force the plug (23) into the stem (1.).
- Fix the plug in this position.
- Insert the retaining ring (26) into the gap between the stem and the plug (2.).
- Use a screwdriver to force the retaining ring into the groove in the stem (3.).

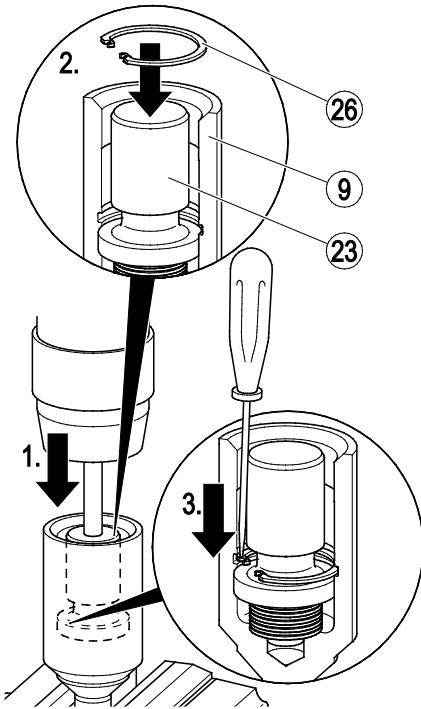

- Slowly loosen the plug.
- Take the stem out of the clamping device.

## Installing inner parts



### DANGER

Risk of bruises if the equipment or component parts fall down.

- Use suitable lifting gear when moving or lifting the equipment and/or component parts.
- Make sure that the equipment cannot topple over.
- Make sure that nobody is standing below the lifted equipment.

### Attention!

Equipment may not work properly or get damaged if parts are tilted or skewed when installed.

- Use suitable lifting gear to mount the component parts.
- Do not tilt or skew the component parts during installation.
- During installation make sure that the component parts are not damaged by physical shocks.

The required bearing capacity of the lifting gear depends on the equipment type. Contact the manufacturer for more information on the weights of the individual parts.

Assemble the shown nozzle parts outside the valve body.



- Put the seat bushing (22) into the body (1.).
- Put the ring (20) with the groove over the shoulder on the seat bushing (2.).
- Place the lower main gasket (19) on the ring (3.).

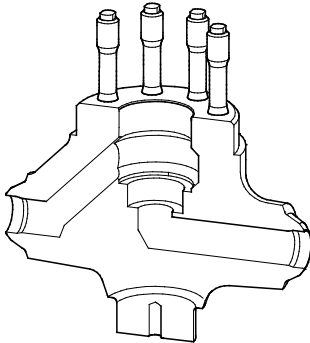
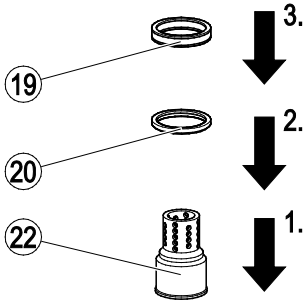

- Put the pressure element (18) on the seat bushing and the lower main gasket (4.).
- Put the throttle unit (21) on the pressure element (5.).
- Place the upper main gasket (17) on the throttle unit (6.).

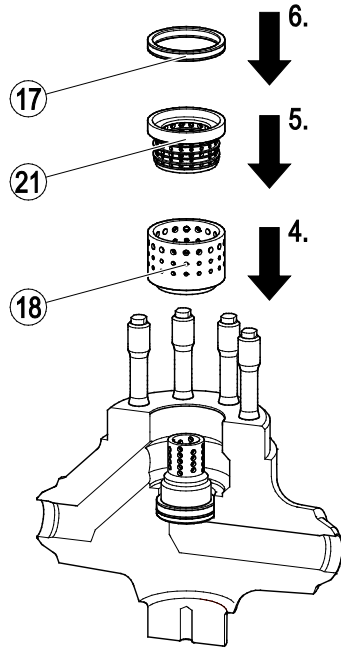

You can also assemble the insert outside of the valve body and then use the extraction tool kit to fit it in the valve body.

- Mount the insert in the specified order.
- Fit the extraction tool to the body as described in section "*Removing inner parts*" from page 32 onwards.
- Mount the assembled insert, in reverse order of removing, in the body.

## Mounting the gland packing

### **Attention!**

Malfunctions may occur if the packing rings are fitted incorrectly.

- Make sure that the packing rings (15) of the stuffing box are inserted in the following order:

- ▶ one wiper ring made from graphite and CrNi
- ▶ pure graphite rings
- ▶ one wiper ring made from graphite and CrNi



The number of pure graphite rings depends on the size of the equipment. The exact number is indicated in the parts list.

- For more detailed information please contact the manufacturer.

### **Attention!**

Malfunctions may occur if the packing rings are damaged.

- Before installation discard and replace any damaged packing rings.
- Make sure that the packing rings are correctly positioned and not damaged or skewed when fitted.

- Put the stuffing box ring (48) into the upper part.
- Put the packing rings (15) into the upper part.
- Put the packing gland (47) into the upper part.

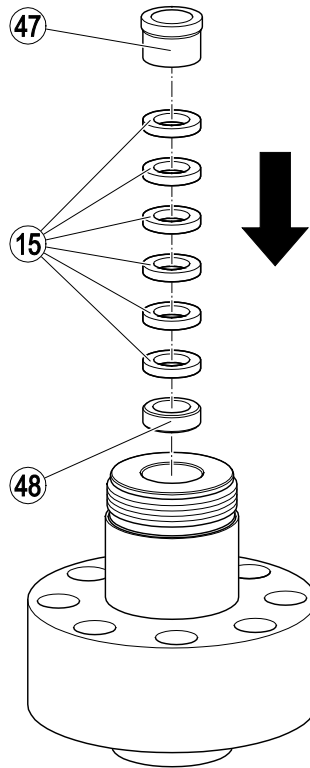

- Screw the screwed union (12) loosely into the upper part.
- Put the packing ring (15) into the screwed union.
- Put the support disk (14) into the screwed union.
- Put the retaining ring (13) into the groove of the screwed union.
- Tighten the screwed union (12) hand tight.

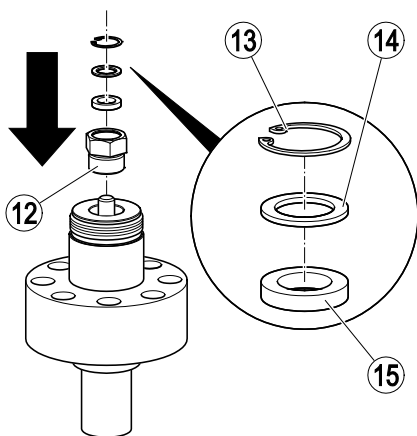

## Fitting the upper part



### DANGER

Risk of bruises if the equipment or component parts fall down.

- Use suitable lifting gear when moving or lifting the equipment and/or component parts.
- Make sure that the equipment cannot topple over.
- Make sure that nobody is standing below the lifted equipment.

- Mount the stem and plug.
- Mount the stuffing-box packing.
- Make sure that the screwed union (12) is slightly slackened.
- Slowly pull the stem (9) upwards until it hits the stop and hold the stem in this position.
- Put the upper part (16) with the stem onto the stud bolts (40) in the body (1.).

When inserting the stem with plug in the insert, ensure that it is not canted and that it does not hit any part.

- Screw the hexagon nuts (39) on and tighten them until they are handtight (2.).
- Tighten the hexagon nuts in diagonally opposite pairs to a torque of 300 Nm.
- Tighten the screwed union (12) (3.).

The torque required for tightening the screwed union depends on the condition of the stuffing-box packing. Tighten the screwed union until the following requirements are met:

- ▶ The stuffing box must not leak.
  - ▶ The movement of the stem must not be impaired by the stuffing box.
- If it is not possible to meet both requirements you have to replace the stuffing-box packing.

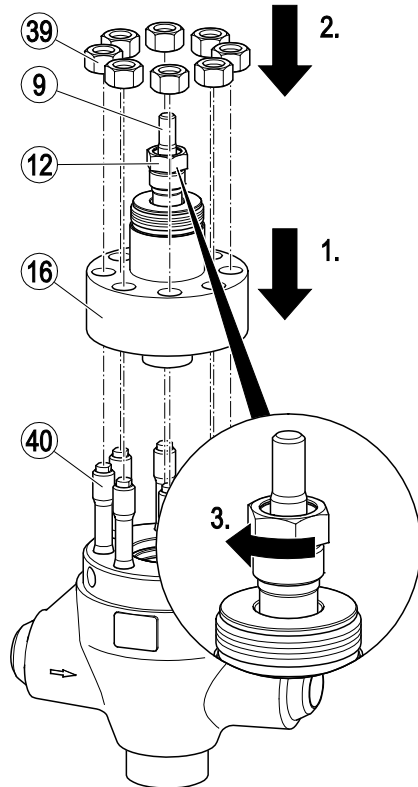

## Attaching the cap and actuator



This section describes installation in standard equipment.

In equipment with a pneumatic actuator, the cap is part of the actuator. You can find installation instructions for this type of equipment in section "*Fit the cap and pneumatic actuator.*" on page 49.



The attachment of the bonnet to the body depends on the type of actuator. Valves with pneumatic actuator feature a groove nut with which the bonnet is fixed. All other types of actuator use grub screws for attaching the bonnet to the valve body. The following two sections describe the mounting options in more detail.



### **DANGER**

Risk of bruises if the equipment or component parts fall down.

- Use suitable lifting gear when moving or lifting the equipment and/or component parts.
- Make sure that the equipment cannot topple over.
- Make sure that nobody is standing below the lifted equipment.

## Mounting the bonnet

- Put the bonnet (2) onto the body with upper part.
- Apply MoS2 grease to the threads of the grub screws (35).-
- Tighten the screws hand tight in diagonally opposite pairs.

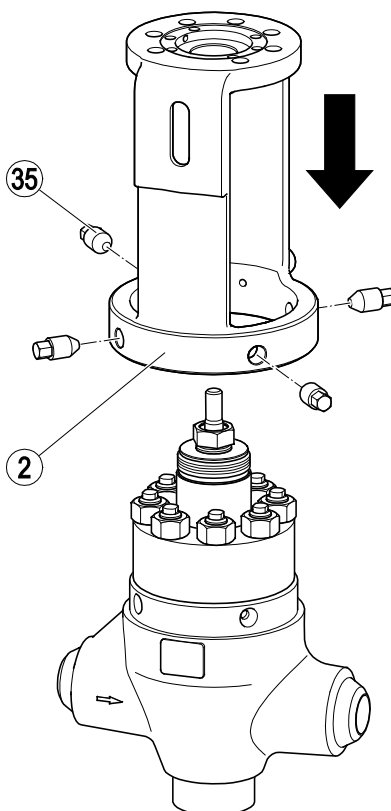

### **Attention!**

Equipment may not work properly or get damaged if screws, nuts or bolts are tightened with the wrong torques.

- Tighten the screwed union to the following torque:

- Tighten the screws and grub screws with a torque of 80 Nm.

### Mounting the spindle bearing and the actuator

- i** The work required for mounting the actuator depends on the actuator type. Proceed in reverse order of disassembling the equipment.  
The following drawing shows the equipment for a rotary actuator.

---

#### **Attention!**

Stem may get damaged if the spindle protrudes too much.

- Screw the spindle further into the spindle bearing.

---

#### **Attention!**

Equipment may not work properly or get damaged if screws, nuts or bolts are tightened with the wrong torques.

- Tighten the screwed union to the following torque:

---

The torque depends on the type of actuator:

- ◆ Handwheel operation and rotary actuator ZK 313/11: 50 Nm
- ◆ Electric rotary actuator ZK 313/12: 200 Nm
- In equipment with rotary actuator put the spindle bearing (33) with the spindle (7) screwed in place onto the yoke.
- Fasten the spindle bearing with the screws (34).

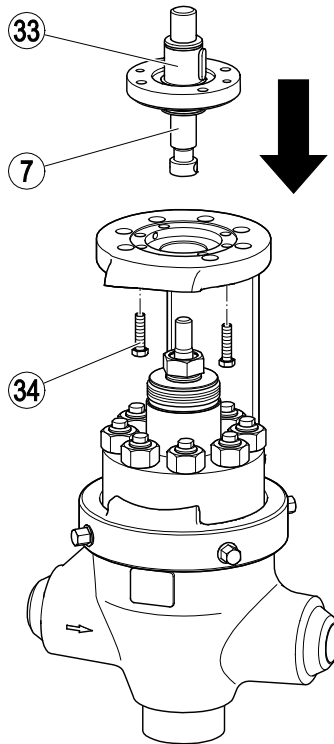

**i** For reasons of clarity, the following drawing shows the equipment without the actuator.

- Put the actuator onto the bonnet.
- Insert the stud bolts (30) through the spindle bearing and the bonnet in the actuator.
- Fix the stud bolts with washers (31) and nuts (32).
- Tighten the nuts to the specified torque.

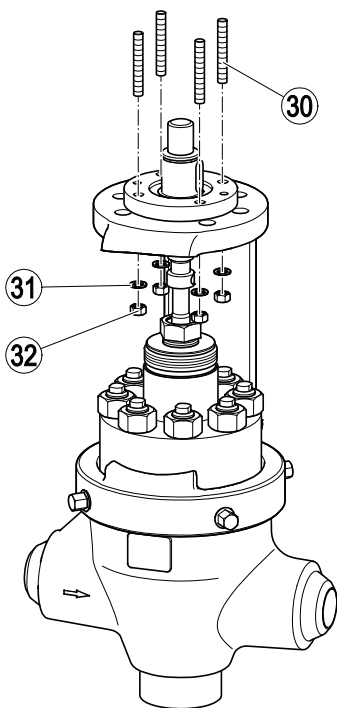

## Mounting the coupling

- Rotate the spindle (7) and the stem (9) so that they lie flush against one another without pressure.
- Place the two halves of the coupling (8) around the stem and spindle as shown.
- Secure the spindle and coupling parts with a hexagon head bolt (28).
- Screw in the other hexagon head bolts (28).
- To align the coupling with the thread of the stem, rotate the stem and coupling a little and slightly tighten the lower bolts.
- Insert the scale marking (10) in the coupling.

The scale marking (10) must be situated next to the scale in the cap recess.

- To align the coupling, rotate it and the stem.

### **Attention!**

Equipment may not work properly or get damaged if screws, nuts or bolts are tightened with the wrong torques.

- Tighten the screwed union to the following torque:

Screwed-union of the coupling: 20 Nm.

- Attach the washers (29) and the hexagon nuts (27) to the hexagon-head cap screws.
- Tighten the hexagon nuts (27) to the specified torque.

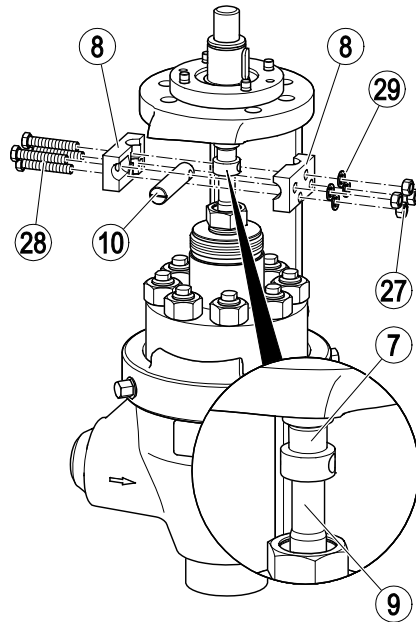



## Fit the cap and pneumatic actuator.



If the equipment is fitted with a pneumatic actuator, the bonnet (here called yoke) is an elemental part of the actuator.

In this type of equipment the bonnet is called "yoke".



### DANGER

Risk of bruises if the equipment or component parts fall down.

- Use suitable lifting gear when moving or lifting the equipment and/or component parts.
  - Make sure that the equipment cannot topple over.
  - Make sure that nobody is standing below the lifted equipment.
- 
- Put the distance ring (37) over the upper part (1.)
  - Place the actuator with yoke (2) onto the distance ring (2.).
  - Put the groove nut (36) onto the upper part.
  - To attach the yoke to the upper part, fasten the groove nut (3.).
  - Screw the screw-in adapter (38) onto the stem (4.).
  - Tighten the locknuts hand tight to the screw-in adapter.

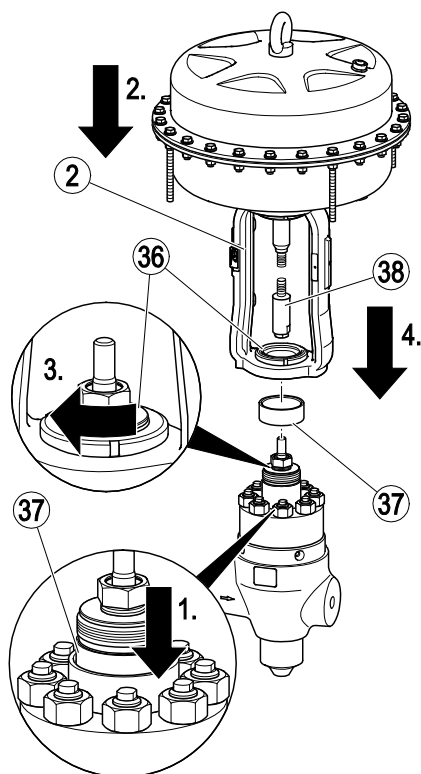

### Attention!

Equipment may not work properly or get damaged if parts of the actuator are not properly aligned.

- Make sure that the stem or the screw-in adapter are in proper alignment with the actuator spindle.
- 
- Attach the actuator spindle by means of the coupling to the screw-in adapter or stem of the equipment.

## Connecting the actuator

- Connect the actuator properly to its power supply.

## Servicing the equipment and installing spare parts

You may exchange the following component parts in case of wear or damage:

-  The material specification and stock code numbers of the component parts are indicated in the supplied parts list.
- Disassemble the equipment as described from page 26 onwards.
- Remove the defective component part from the equipment.

---

### ***Attention!***

Equipment may leak if the gaskets are damaged.

- Always insert new main gaskets when assembling the equipment.
  - Check all gaskets, seals and packing rings before installing them.
  - Replace any damaged gasket, seal or packing ring.
- 
- Mount the new component part.
  - Check all component parts before re-installing them.
  - Replace the defective component parts.
  - Replace the two main gaskets.
  - Re-assemble the equipment as described from page 38 onwards.

## Troubleshooting

| <b>Problem</b>                            | <b>Cause</b>                                                                                           | <b>Remedy</b>                                                                                                                          |
|-------------------------------------------|--------------------------------------------------------------------------------------------------------|----------------------------------------------------------------------------------------------------------------------------------------|
| The stem moves with difficulty or jerky.  | Malfunction in actuator.                                                                               | Follow the instructions in the operating manual for the actuator.                                                                      |
| The actuator switches off automatically.  | Malfunction in controller.                                                                             | Follow the instructions in the operating manual for the controller.                                                                    |
|                                           | The stuffing box packing affects the stem lift.                                                        | Slightly loosen the stuffing-box screw.<br>Replace the stuffing box packing if it keeps affecting the stem lift.                       |
| The flowrate is too small.                | The stem lift is affected by foreign matter.<br>The nozzles are dirty or clogged by foreign particles. | Rinse the installation.<br>If necessary disassemble the equipment and clean the component parts.                                       |
| During operation loud noises are audible. | The nozzles are dirty or clogged by foreign particles.                                                 |                                                                                                                                        |
| The stuffing box is leaking.              | The stuffing box has not been tightened enough.                                                        | Tighten the stuffing box screw.<br>Make sure that the stuffing box does not impair the movement of the stem and that it does not leak. |
|                                           | The stuffing-box packing is damaged.                                                                   | Replace the stuffing-box packing.                                                                                                      |

- If faults occur that are not listed above or cannot be corrected, please contact our Technical Service or authorized agency in your country.

## Putting the equipment out of operation

### Removing harmful substances



#### **DANGER**

If the equipment is used in contaminated areas there is a risk of severe injuries or death caused by harmful substances in or on the equipment.

- Only qualified personnel are allowed to perform work on contaminated equipment.
- Always wear the protective clothing prescribed for contaminated areas when working on the equipment.
- Make sure that the equipment is completely decontaminated before carrying out any service work.
- Follow the pertinent instructions for handling the hazardous substances in question.

Qualified personnel must have extensive experience with and a working knowledge of:

- ◆ pertinent rules and regulations concerning handling hazardous substances
- ◆ special regulations for handling the hazardous substances encountered on site
- ◆ using the required personal protective equipment (PPE) and clothing



#### **Caution**

Environmental damage may be caused by poisonous fluid residues.

- Before disposing of the equipment make sure that it is clean and free of fluid residues.
  - For the disposal of all materials observe the pertinent legal regulations concerning waste disposal.
- 
- Remove all residues from the equipment.
  - For the disposal of all residues observe the pertinent legal regulations concerning waste disposal.

### Removing the equipment



#### **DANGER**

Personnel working on pipes are exposed to safety risks and may suffer severe injuries, poisoning or even loss of life.

- Make sure that no hot or hazardous fluid is in the equipment or the pipes.
- Make sure that the pipes upstream and downstream of the equipment are depressurised.
- Make sure that the installation is switched off and protected against unauthorised or unintended activation.
- Make sure that the equipment and the pipes have cooled down to room temperatures.
- Wear protective clothing that is suitable for the fluid and, if necessary, wear protective gear.

For more information on suitable protective clothing and safety gear refer to the safety data sheet of the fluid in question.



## DANGER

Risk of bruises if the equipment or component parts fall down.

- Always wear protective gear when working on the equipment.
- Use suitable lifting gear when moving or lifting the equipment and/or component parts.
- Make sure that the equipment cannot topple over.
- To lift the equipment use only the valve body or the bonnet.
- Make sure that nobody is standing below the lifted equipment.

The protective gear must comprise at least the following:

- ◆ Safety helmet to EN 397
- ◆ Safety footwear to EN ISO 20345
- ◆ Protective leather gloves to EN 388

For more information on suitable safety clothing and safety gear refer to the safety data sheet of the fluid in question.

The lifting gear must be of sufficient strength for the equipment including the actuator.

For more information on the weight of the equipment see the attached documents. For more information on the weight of the actuator see the documents provided by the actuator manufacturer.

- Switch the installation off and protect it against unauthorised or unintended re-activation.



## WARNING

Risk of severe injuries or death if the actuator is not removed correctly.

- Before working on the actuator cut off power supply to the actuator.
- Follow all instructions and observe all notes given in the operating manual for the actuator.
- Make sure that only qualified and trained personnel work on the actuator and its connections.

A qualified person must be acquainted with and experienced in the following:

- ◆ safety issues when working on the installation
- ◆ establishing connections with the respective power source of the actuator
- ◆ mechanical work on pipes.
- Cut off the power supply to the actuator.
- Detach the actuator from the mechanical connection of the equipment.
- Detach the end connections of the equipment from the pipes.
- Put the equipment onto a suitable base.

The base must be sufficiently strong to withstand the weight of the equipment.

- If necessary disassemble the equipment and put down individual parts.
- Store the equipment as described on page 16.

## Disposing of the equipment

---



### Caution

Environmental damage may be caused by poisonous fluid residues.

- Before disposing of the equipment make sure that it is clean and free of fluid residues.
  - For the disposal of all materials observe the pertinent legal regulations concerning waste disposal.
- 

### Materials

| Component          | EN     | ASME    |
|--------------------|--------|---------|
| Body               | 1.0460 | A105    |
|                    | 1.5415 | –       |
|                    | 1.7383 | A182F22 |
|                    | 1.4903 | A182F91 |
| Upper part of body | 1.0460 | A105    |
|                    | 1.4903 | A182F91 |
| Threaded bolt      | 1.7709 | A193B16 |
|                    | 1.4980 |         |
| Nuts               | 1.7709 | A194-7  |
|                    | 1.4980 |         |

## Technical data

### Dimensions and weights

For information on dimensions and weights please see data sheet.

For information on dimensions and weights of the actuator please refer to the documents provided by the manufacturer of the actuator.

- For more information please contact the manufacturer.

# Fluid flowrate and differential pressure

Flowrates, cold water

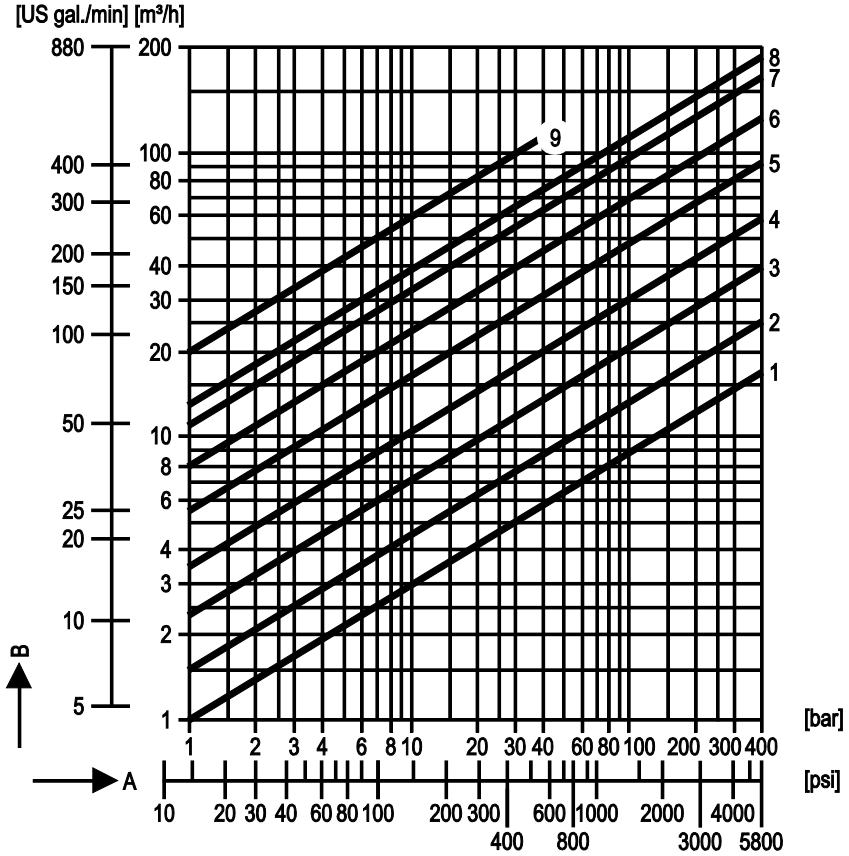

A Differential pressure

B Flowrate

|   | <b>K<sub>v</sub>s value</b> | <b>C<sub>v</sub> value</b> |
|---|-----------------------------|----------------------------|
| 1 | 1                           | 1.2                        |
| 2 | 1.5                         | 1.7                        |
| 3 | 2.3                         | 2.7                        |
| 4 | 3.6                         | 4.2                        |
| 5 | 5.5                         | 6.4                        |
| 6 | 8                           | 9.4                        |
| 7 | 11                          | 12.7                       |
| 8 | 13                          | 15.0                       |
| 9 | 20                          | 23.1                       |



**Flowrates, hot water, ts-5 K**

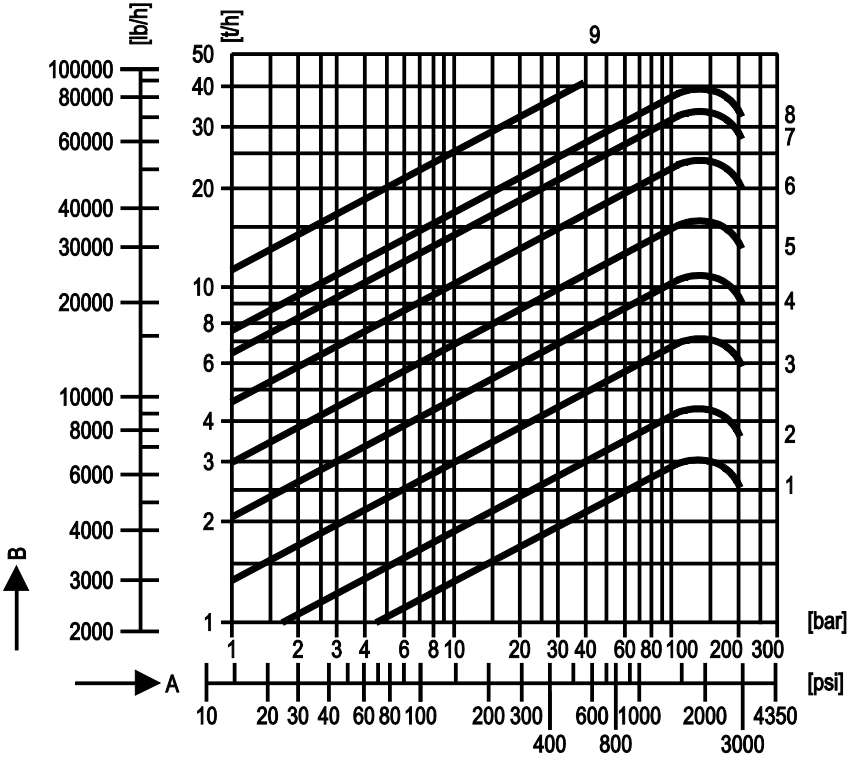

A Differential pressure (assuming discharge to atmospheric pressure)

For higher back pressure take a correction factor into account. The ascertained flowrate is reduced by the correction factor.

B Flowrate

|   | <b>Kvs value</b> | <b>Cv value</b> |
|---|------------------|-----------------|
| 1 | 1                | 1.2             |
| 2 | 1.5              | 1.7             |
| 3 | 2.3              | 2.7             |
| 4 | 3.6              | 4.2             |
| 5 | 5.5              | 6.4             |
| 6 | 8                | 9.4             |
| 7 | 11               | 12.7            |
| 8 | 13               | 15.0            |
| 9 | 20               | 23.1            |

### Back pressure diagram

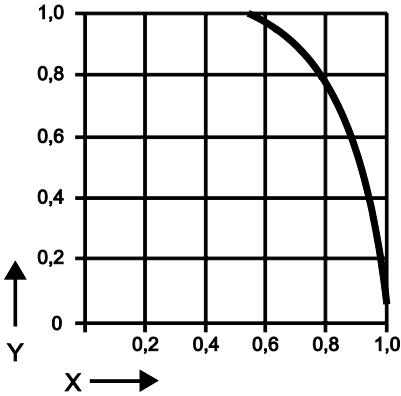

- Y Correction factor
- X Pressure ratio  $p_2/p_1$  (absolute)

 For more information see data sheet.

### Pressure & temperature ratings

 The following specifications refer to the equipment and not to the end connection.

- Please contact the manufacturer for more information on the application limits dictated by the type of end connection used.

### Admissible differential pressure $\Delta PMX$

|                                            | [bar] | [psig] |
|--------------------------------------------|-------|--------|
| <b>Single stage</b>                        | 40    | 580    |
| <b>Three stages</b>                        | 300   | 4,350  |
| <b>Three stages with additional nozzle</b> | 370   | 5,365  |

### Maximum pressure

You can find precise information on the pressure and temperature ratings of your equipment on the name plate and in the data sheet.

### Manufacturer's Declaration

You can find details on the conformity assessment in accordance with European Directives in our Declaration of Conformity or our Declaration of Incorporation.

To request the valid Declaration of Conformity or Declaration of Incorporation, please contact:

#### GESTRA AG

Münchener Straße 77

28215 Bremen

Germany

Telefon +49 421 3503-0

Telefax +49 421 3503-393

E-Mail [info@de.gestra.com](mailto:info@de.gestra.com)

Web [www.gestra.de](http://www.gestra.de)

This declaration is no longer valid if modifications are made to the equipment without consultation with us.





Agencies all over the world: [www.gestra.de](http://www.gestra.de)

## **GESTRA AG**

Münchener Straße 77

28215 Bremen

Germany

Telefon +49 421 3503-0

Telefax +49 421 3503-393

E-Mail [info@de.gestra.com](mailto:info@de.gestra.com)

Web [www.gestra.de](http://www.gestra.de)

818542-04/07-2017 kx\_mm (808600-05) © GESTRA AG Bremen Printed in Germany